

SXO-1612HG

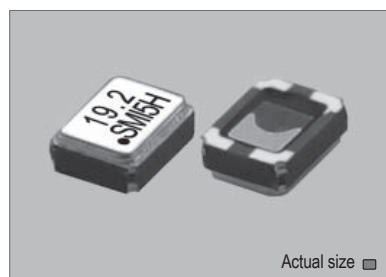

Actual size 0.005 gm (wt.)

SXO-1612HG

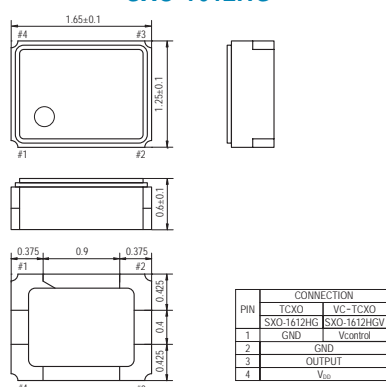

OUTPUT WAVEFORM

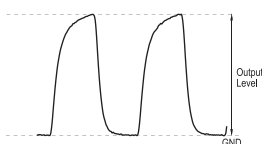

SOLDERING PATTERN

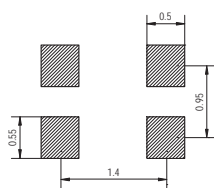

TEST CIRCUIT

SXO-1612HG

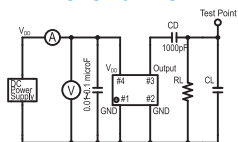

CD : DC-Out capacitance
RL : 10kΩm ± 10%
CL : 10pF ± 10% including fixture and probe capacitance

SXO-1612HGV

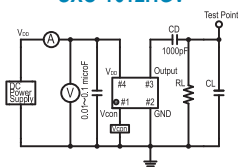

CD : DC-Out capacitance
RL : 10kΩm ± 10%
CL : 10pF ± 10% including fixture and probe capacitance

STANDARD SPECIFICATIONS

● CLIPPED SINE WAVEFORM
● PACKAGE SIZE 1.6x1.2 mm

Item	Specifications	
General part number	SXO-1612HG* ¹	SXO-1612HGV* ¹
Frequency range	19.200 MHz to 52.000 MHz	
Initial frequency tolerance at +25°C ±2°C	±1.5 ppm max.* ²	±1.5 ppm max. (Vcon = 1/2 VDD)* ²
TCXO or VC-TCXO	TCXO	VC-TCXO
Frequency Stability	Temperature range	±0.5 ppm max. over -30°C to +85°C (referred to +25°C)* ³
	Input voltage change	±0.1 ppm max. at VDD ±5% DC
	Output load change	±0.1 ppm max. at 10 kΩ ±10% with 10 pF ±10%
	Aging	±1 ppm max. per year at +25°C ±3°C
Operating Conditions	Operating temperature	-30°C to +85°C (Standard) -40°C to +85°C (W = Option, frequency dependent)
	Supply voltage (VDD)	D = +1.8V, F = +2.5V, H = +2.8V (Standard), J = +3.0V, K = +3.3V DC ±5%
	Control voltage (Vcon)	n.a. +0.9V ± 0.8V (VDD = +1.8V) 1/2 VDD ± 1V DC (VDD = +2.5V to +3.3V)
Absolute Max. Ratings	Supply voltage	-0.6V to +4.6V DC
	Vcontrol voltage (Vcon)	n.a. -0.6V to VDD +0.6V DC
	Storage temperature	-40°C to +85°C
Input current	1.5 mA max. (19.200 MHz to 30.000 MHz) 1.7 mA max. (30.000 MHz to 52.000 MHz)	
Output (-40°C to +85°C)	Level	0.8 Vp-p min.
	Load	10 kΩ // 10 pF
	Waveform	Clipped sine wave (DC-coupling)
Frequency adjustment voltage control (Vcon)	n.a.	±8 ppm to ±13 ppm (VDD = +1.8V) ±9 ppm to ±15 ppm (VDD = +2.5V to +3.3V) Positive
Frequency slope	n.a.	
Harmonic distortion	-5 dBc max.	
Start-up time	2 ms max. (Vout ≥ 90%Vp-p)	
SSB phase noise	-135 dBc / Hz, Typical at 1 kHz offset	
IR reflow resistance	±1 ppm max. (referred to frequency before reflow)	
Reflow condition	+250°C ±10°C for 10 seconds +170°C ±10°C for 1 to 2 minutes (preheating)	
Standard frequencies (MHz)	19.200, 26.000, 38.400, 52.000	
Optional Operating Temperature* ⁴	Low limit / Symbol	-10°C / g -15°C / h -20°C / i -25°C / j -30°C / k -35°C / l -40°C / m
	High limit / Symbol	+55°C / ff +60°C / gg +65°C / hh +70°C / ii +75°C / jj +80°C / kk +85°C / ll

(*¹) Final part number to be assigned with package type, TCXO or VC-TCXO, input voltage, operating temperature and frequency. e.g. SXO-1612HG-D-S-26MHz.
(*²) Referred to nominal frequency before reflow soldering.
(*³) At Vcon = 1/2 VDD DC for SXO-1612HGV.
(*⁴) Select "low limit" and "high limit" for new operating temperature combination from the lists.

PACKAGE DATA

Item	Package	SXO-1612HG
Lid		Metal
Base		Ceramic
Sealing		Seam
Terminal		Tungsten (metalized)
Terminal plating		Gold / Nickel (surface) / (under)
RoHS		Compliant (Pb-free)

TAPE SPECIFICATIONS

